

Roll No							
---------	--	--	--	--	--	--	--

B.E. / B.Tech. (Full Time) DEGREE END SEMESTER EXAMINATIONS, MAY 2011
 COMMON TO MECHANICAL/MANUFACTURING/PRINTING/MINING ENGINEERING BRANCH
 SECOND SEMESTER – (REGULATIONS 2008)

EE9166 – BASIC ELECTRICAL ENGINEERING AND MEASUREMENTS

Time: 3 hrs.

Max.Mark: 100

Answer ALL Questions

Part – A (10 × 2 = 20 Marks)

1. Write the sign convention to be followed while using Kirchoff's Voltage law.
2. How are the inductive reactance and capacitive reactance affected by the change of frequency?
3. What are the three main characteristics of a DC generator?
4. Why single phase induction motor is not self starting?
5. List out the sources of errors in moving coil instruments.
6. What is the use of Megger ?
7. Mention the classifications of transducers?
8. What is Piezo electric effect?
9. Define active filter.
10. What is LCR bridge and draw its skeleton diagram ?

Part – B (5 × 16 = 80 Marks)

- 11.(i) Explain the working of a Digital to Analog (D/A) Converter with an example. (8)
- (ii) Give a brief description about CRT display with neat diagram. (8)
- 12a. (i) For the circuit shown in fig.(i) determine the current flowing through R_3 resistor using Kirchoff's laws. (8)

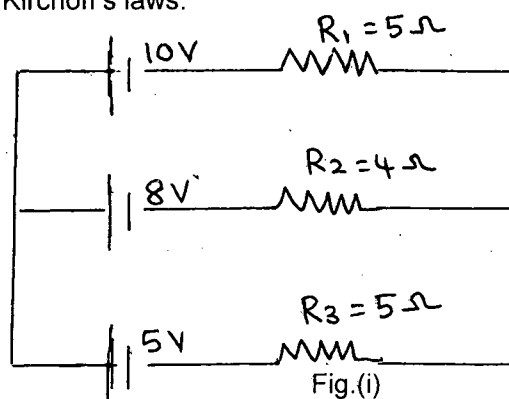

(Or)

- b) Assume that you are working as an Assistant Engineer in Alpha Construction Company. In the construction site, there was a fire accident at midnight because of short circuit. In the accident, there was a huge loss to the company. Write a letter with a detailed report to the Chief Engineer about the accident and the steps that can be taken to avoid such fire accidents in the future. (16)

13. a) Imagine that you are living in a village. The quality of education in your village school is not good. Parents are very much worried about the standard of education. Write a set of eight recommendations to improve the quality of education in the school. (16)

(Or)

b) Assume that the bus-stand in your town is unclean. People in the town are not happy with the maintenance work in the bus-stand. In addition, there is no drinking water facility. Write a set of eight recommendations to improve cleanliness and facilities in the bus-stand. (16)

14. a) You are the NSS Program Officer in your college. You have been asked to conduct a 3-day camp in a village near Chennai. Prepare a checklist of eight important items that you arrange for the camp. (16)

(Or)

b) Imagine that your Department is conducting a 2-day workshop on 'Soft Skills' next month for the first year B.E. / B.Tech. students. You have been assigned with the task of distributing stationery items and collecting registration fee. Prepare a check list of eight important items that need to be kept in the registration- cum- reception counter. (16)

15. Write two paragraphs on any **ONE** of the following topics. Each paragraph should not exceed 150 words.

a) Unemployment problems in rural areas (16)

(Or)

b) Library and its uses (16)