

--	--	--	--	--	--	--	--	--	--

Full-Time B.E./B.Tech. DEGREE EXAMINATIONS, MAY 2011

II – Semester, Regulations 2008

(Common to ALL Branches of Engineering & Technology of University Departments of CEGC, A.C.Tech., and MIT Campuses of Anna University, Chennai – 25)

Also common to II Semester B.E. (Mechanical and Civil – Tamil Medium)

GE 9151 – Engineering Mechanics

Duration: 3-Hours

Max. Marks: 100

Answer ALL questions

Part – A (10X2 = 20 marks)

- Find the magnitude and the direction of the following forces acting at a point
 $F_1 = 20 i + 30 j$ Units
 $F_2 = -10 i - 50 j$ Units
- What are equilibrium conditions to be satisfied for a particle applied with a system of non-coplanar, concurrent forces?
- Draw the free-body diagram for the problem shown in Fig. 3.

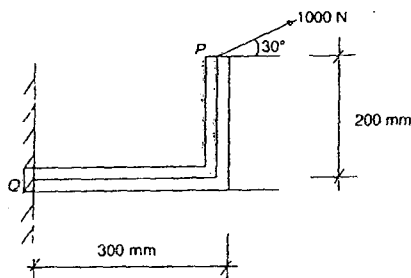

Fig. 3

- Two forces $F_1 = 5 i$ N; $F_2 = 8.66 j$ N, are passing through a point whose coordinates are (2,1) m. Calculate the moment of these forces about the origin.
- State the Pappus-Guldinus Theorem -1?
- Find the area moment of inertia about the centroidal axes for the section shown in Fig. 6

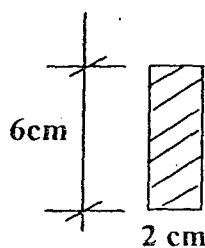

Fig. 6

- A lift starts and accelerates at a constant rate of 3 m/s^2 . What is the velocity of the lift after it has travelled to a distance of 13.5 m?
- A body of mass 5 kg accelerates at a constant rate of 2 m/s^2 on a smooth horizontal surface due to external force acting at 30° with the horizontal. Find the magnitude of the force.
- State any two important laws of dry friction.
- What is the angle turned by a wheel while it starts from rest and accelerates at a constant rate of 3 rad/s^2 for an interval of 20 s?

Part – B (5 X 16 = 80 marks)

Q11 compulsory & from Q12 onwards answer either (a) or (b)

- 11 Locate the centroid for the shaded area shown in Fig. 11. (16)

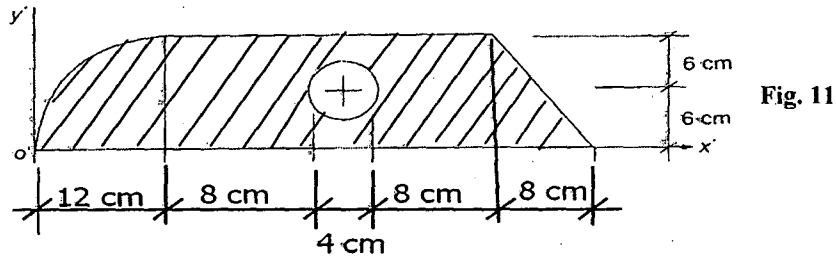

- 12a) Find the reactions at supports 'A' and 'E' for the Problem shown in Fig. 12a.

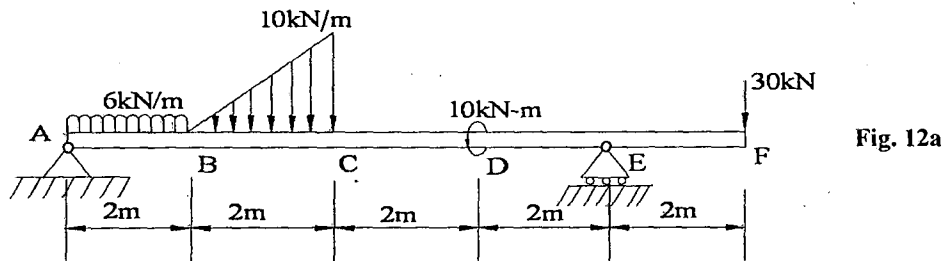

[OR]

- 12b) 2000N vertical load is applied at the end 'Q' of the rod QR whose length is 200mm. A weight of $W=2000\text{N}$ is hung with the help of a cord connected at point 'Q' passing over a smooth pulley at point 'P'. For equilibrium, find angle θ and reactions at point 'R' (Refer Fig. 12b)

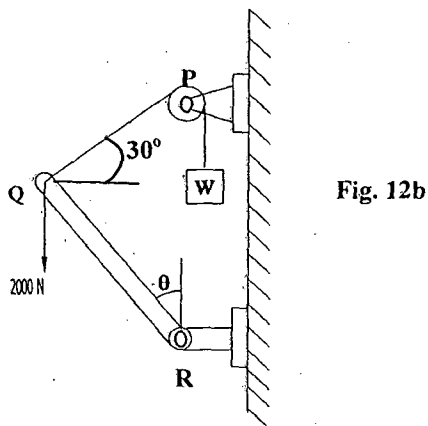

- 13a i) Two cables are tied together at point 'O' and loaded as shown in Fig. 13a (i) (8)
Determine the tension in OO_1 and OO_2 .

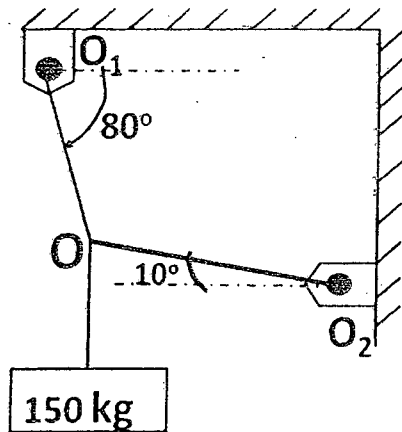

Fig. 13a (i)

- ii) A stone of weight 500 N as shown in Fig. 13a (ii) is supported against to (8)
plane surface which is perpendicular to the 45° inclined surface. Find the
reactions at the contact points.

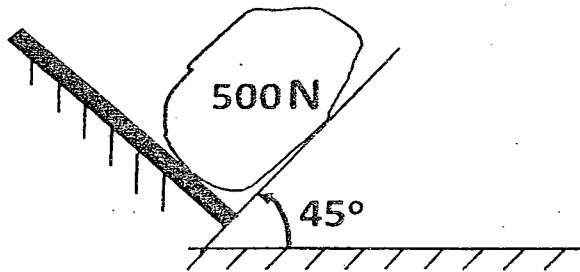

Fig. 13a (ii)

[OR]

- 13b A cylinder of weight $W=1500$ N is supported by three cables as shown in (16)
Fig.13b. Determine the tension in each cable.

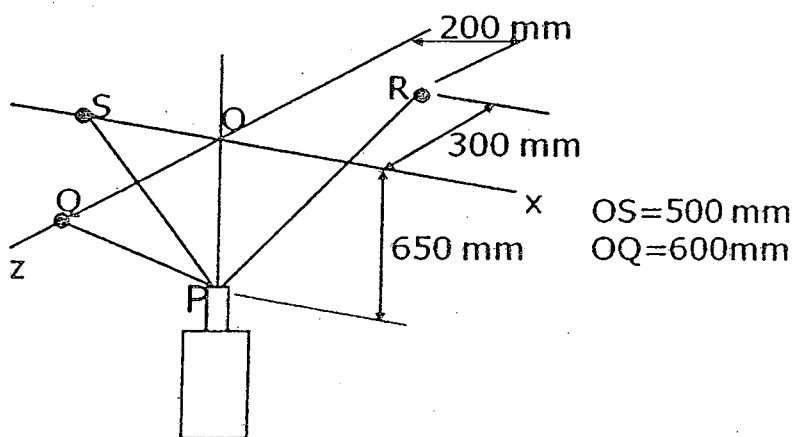

Fig. 13b

- 14a (i) A man is standing on a bridge and a stone is thrown by him vertically upwards with a velocity 15 m/s. If it strikes the water after 3.5 s, determine (10)
 (i) the height of the bridge with respect to the water level and (ii) the speed with which the stone strikes the water.

- (ii) A man throws a stone with an initial velocity of V_i of 15 m/s from a point P to target a mango from a tree at point Q, which is located at the height of 12 m from the ground as shown in Fig. 14a-ii. Find the corresponding angle θ . (6)

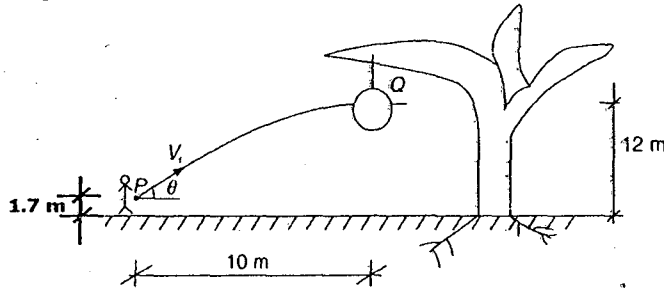

Fig. 14a-ii

[OR]

- 14b A 300 N block shown in Fig. 14b slides from 50° inclined surface downwards. It starts from rest, after moving 2 m; it strikes a spring whose modulus is 20 N/mm. If μ between block and the plane = 0.2, determine the maximum deformation of the spring and the maximum velocity of the block. (16)

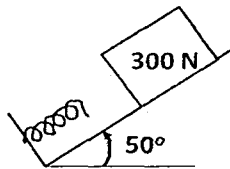

Fig. 14b

- 15a Determine the horizontal force F required for the wedge B to raise the block A of weight 10 kN as shown in the Fig. 15a, if the coefficient of friction on all the surfaces is 0.2. (16)

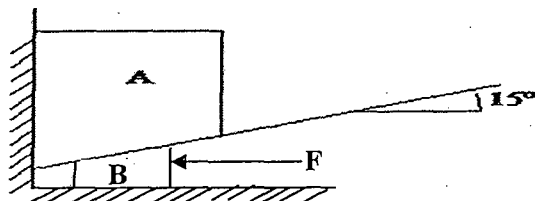

Fig. 15a

[OR]

- 15b A 4 m long uniform ladder weighing 200 N is placed against a wall making an angle of 55° with the floor. The coefficient of friction μ between the wall and the ladder is 0.26 and that between the floor and the ladder is 0.36. The ladder in addition to its own weight has to support a man of 900 N at its top end. Calculate the horizontal force ' F ' applied to the ladder at the floor level to prevent slipping. If force ' F ' is not applied, what will be the minimum inclination of the ladder so that it does not slip when the man is at its top end. (16)