



B.E/ B. Tech DEGREE END SEMESTER EXAMINATIONS, Nov/Dec. 2013

B.E- Printing Technology (FULL TIME)

Common to Mechanical & Manufacturing Engineering

EE - 8251/ Basic Electrical Engineering and Measurements

III - SEMESTER (REG: 2012)

Time : 3 Hours

Max. Mark : 100

Answer ALL Questions

Part-A(10*2 =20 Marks)

1. State Kirchhoff's laws with an example.
2. Draw the circuit diagram for three phase power measurement using two wattmeter method. Assume the load to be inductive.
3. State the need for commutator in DC generator.
4. If high DC supply is given to the transformer, what will happen to the transformer?
5. Why moving coil instrument cannot be used for AC measurement?
6. State the necessary balancing condition for AC bridges.
7. What are the applications of Load cells?
8. Explain Seebeck effect.
9. What is the need for Filters?
10. Why instrumentation amplifiers are necessary?

Part B-(5*16=80 Mark)

11. (i) Explain how A/D and D/A converters are used in signal conditioning purposes. (12)
- (ii) Explain the advantages of LED display over CRT display and mention different types of LED. (Compulsory) (4)
- 12.a. Explain the working principle of Single phase transformer and Single phase Induction motor.
- Or
12. b Explain the various characteristics of DC motors.
13. (a) Explain the theory of power measurement using wattmeter (One wattmeter and two wattmeter methods).
- Or
- 13 (b) Find the currents in all branches shown in Figure .1.

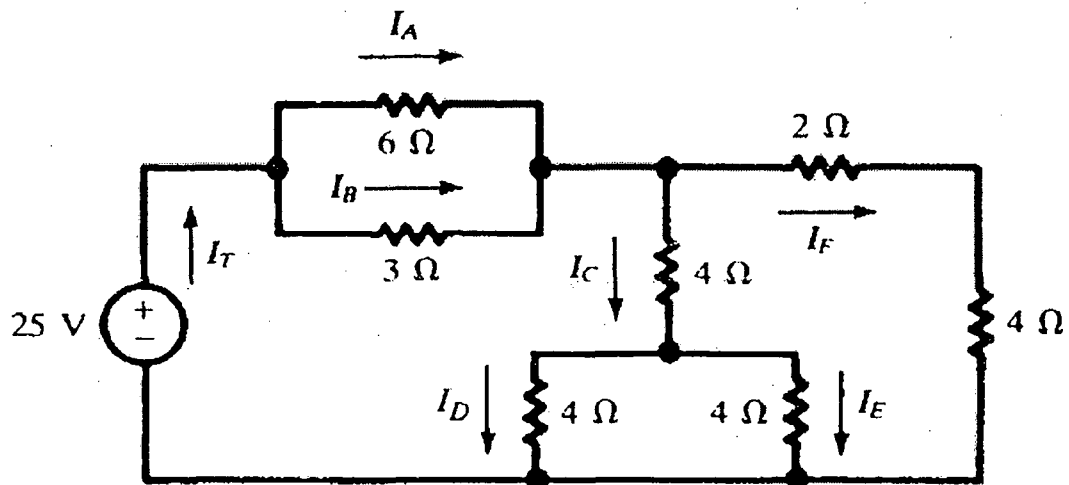

Figure 1 Circuit diagram for Question.13 (b)

Or

- 14.a. (i) Explain the working principle of Maxwell's bridge. (10 Marks)
 (ii) Find the Unknown resistance in the following circuit. (6 Marks)

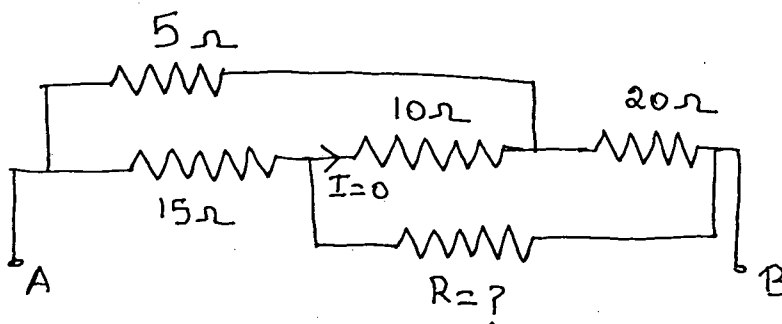

Figure 2. Diagram for Question 14.a(ii)

Or

- 14.b. Explain the working principle of Moving iron instruments and mention its advantages and drawbacks.
- 15.a Explain LVDT . Draw the characteristics and mention its advantages and applications.

Or

- 15.b Explain pH sensors with neat diagram.